

# BLUEPOWER

## WITH HYDROGEN FOR A CLEAN TOMORROW



### ADVANTAGES



H<sub>2</sub> fuel cells as range extenders



Ranges of up to 400 km possible\*\*



Short charging times thanks to hydrogen refuelling in 7-15 minutes\*



Modular tank & fuel cell system

\* depending on tank volume  
\*\* depending on operating conditions

**ON THE MOVE WITH HYDROGEN:  
THE PRINCIPLE OF CLIMATE-NEUTRAL DRIVE TECHNOLOGY**

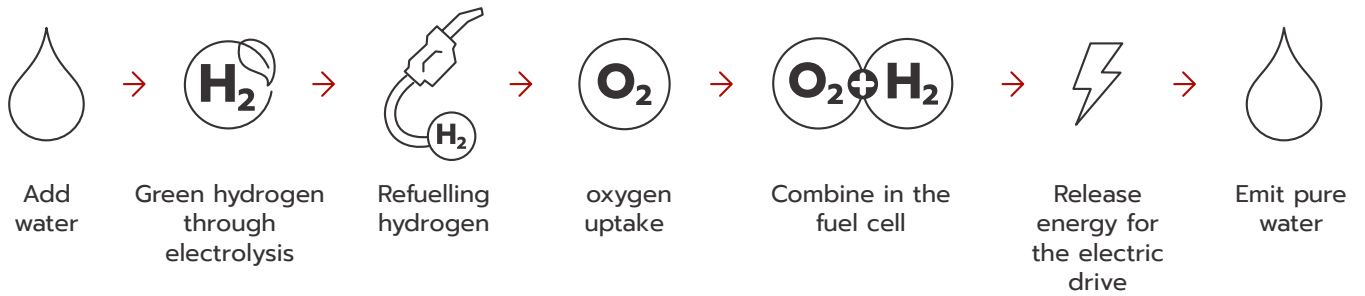

If the necessary BLUEPOWER components are installed in a chassis without conventional drive technology (gliders):

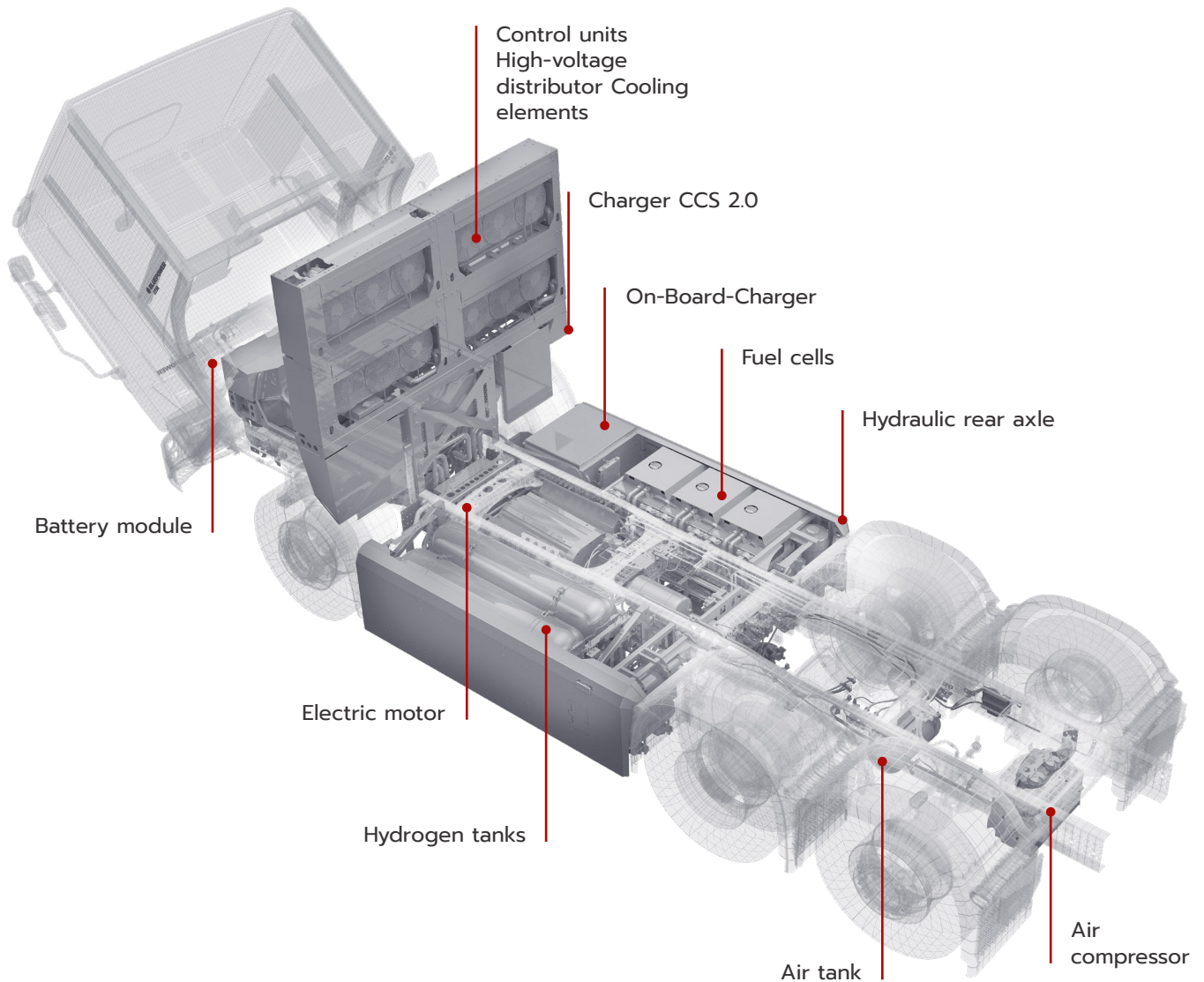

**TECHNIK ENTSCHEIDET.**

## ABOUT THE BLUEPOWER

An emission-free, virtually silent hydrogen drive that, in combination with a fully electric chassis, achieves the operating times and ranges of conventionally powered vehicles. Utilises a glider based on the Mercedes Benz Econic chassis –

in combination with a drive train developed in-house. Ideal for use in the waste disposal industry and for cities, local authorities and waste disposal companies that want to rely on pioneering technology.

## SERIES OPTIONS

### BASIC CONSTRUCTION:

- **Battery pack** with battery capacity of 85 kWh
- **Fuel cells** with optional 30 to 90 kW
- **Hydrogen tanks** with storage capacity from 150 kWh to 600 kWh
- Extendable with various safety & assistance systems

### USE IN COMBINATION WITH:

- X-Family
- All common hydraulic and electric lift systems

Under certain conditions, commercial vehicles with hydrogen fuel cells can be subsidised in Austria:

**ENIN funding:** The FFG subsidises the purchase of hydrogen hydrogen vehicles and the directly associated infrastructure.

**E-mobility for companies, local authorities & associations:** Subsidisation of emission-free commercial & special vehicles by the Kommunalkredit Public Consulting.

Further Information



Funded by  
 **Federal Ministry  
Republic of Austria**  
Climate Action, Environment,  
Energy, Mobility,  
Innovation and Technology



## TECHNIK ENTSCHEIDET.

**STUMMER KOMMUNALFAHRZEUGE**  
Werksgelände 14  
A-5500 Bischofshofen

T: +43 (0) 6462 2557  
stummer@stummer.net  
www.stummer.net